

# EHD500IR

Outdoor Vandal IR Color Dome with 3-Axis and Surface or Flush Mount Capability

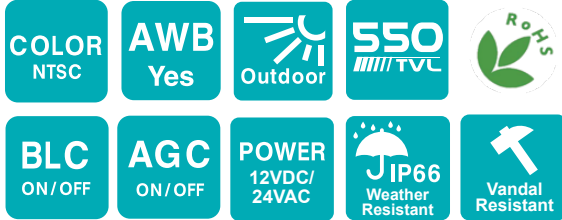

## Features

- 1/3" Sony Super HAD CCD II
- 550 TVL of horizontal resolution
- 3-axis gimbals for desired viewing angle
- Low light sensitivity of 0.05 Lux/F=2.0 (LED Off)
- Weather resistant IP66 rated
- Up to 30 meters /100 feet of IR viewing range
- 30 high illuminating IR LEDs
- Surface or flush mount capabilities
- Vandal resistant to withstand intentional damage
- Vari-focal 2.6~11mm lens
- Suitable for any outdoor surveillance application
- Now able to withstand temperatures up to -40° (F/C)!!!

## Specifications

Video Format	NTSC
Picture Element	NTSC: 768 (H) x 494 (V)
Image Sensor	1/3" Sony Super HAD CCD II
Horizontal Resolution	550 TVL
Electronic Shutter	1/50 (1/60) ~ 1/100,000 sec. (Auto)
Scanning System	2:1 Interlace
S/N Ratio	Over 45 dB (AGC Off)
Sensitivity	0.05 Lux/F = 2.0 (0 Lux/IR On)
Auto White Balance	Yes, (Push/ATW)
Auto Gain Control	Min./Max.
Flickerless	On/Off
Gamma Correction	0.45
Sync. Mode	Internal Sync.
IR LED	30 high LEDs
IR Half Angle	Angle ± 30°
IR Wavelength	850 nm
IR Distance	Up to 30 meters / 100 feet
Lens	Vari-focal 2.6~11mm lens (DC Iris/Mechanical IR Cut Filter Removal)
Power Source	12VDC/24VAC
Power Consumption	12VDC: 8.76W max. / 24VAC: 12W max.
Dimensions (W x H)	Surface Type: 150 x 113.5 mm / 5.9" x 4.5" Flush Type: 143 x 104 mm / 5.6" x 4"
Operating Temp.	-40°C ~ 50°C / -40°F ~ 122° F
Weather Resistant	IP66 Rated
Mount Surface	Mount bracket included

## Dimensions

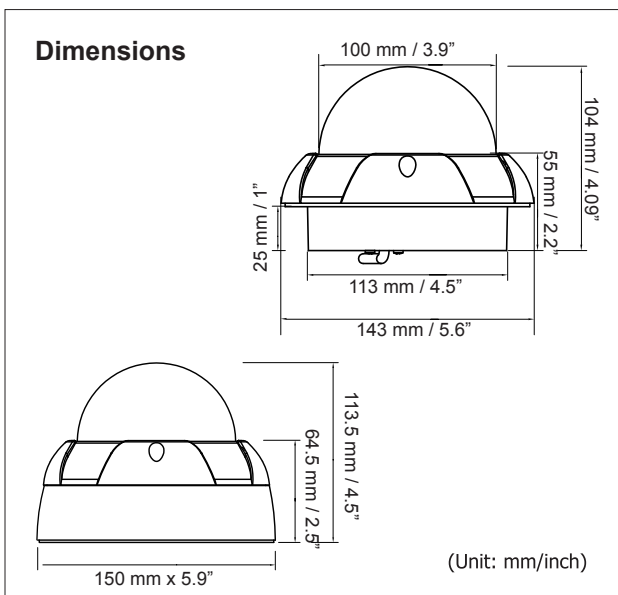

## Ordering Information

- **EHD500IR:** 550 TVL Outdoor Vandal IR Dome, 3-Axis Gimbals, 2.6~11mm Lens

\* Models vary in different countries. Visit [www.everfocus.com](http://www.everfocus.com) and select your country for accurate ordering information